

## GET IN LINE! By Jack Harden

Most boat owners and mechanics know that misalignment between engine and propeller shaft contributes to and may even be the largest cause of vibration and noise in the inboard power train. Aside from the annoyance, dollars are wasted because of higher loading and increased wear.

The customary way of determining if an alignment problem exists is to loosen the engine/shaft coupling and, with feeler gauges, measure the difference in the width between the coupling faces from top to bottom and from side to side in thousands of an inch. Then the measurements are used directly to determine how the engine should be shifted about, and by tilting, raising, lowering and turning the engine on its bed, the gap between the coupling faces is made equal at top and bottom and at each side.

Sometimes the results of this approach are frustrating. After careful adjustment, the vibration remains. The mechanic is sent back to the bilge to repeat the process, and he finds either perfect alignment or a mysterious shift requiring realignment. In the days of predominantly wooden hulls, these mysterious shifts were explained away by blaming the “working” of the hull. But in today’s fiberglass world that explanation doesn’t apply.

What actually happens in these cases is that an uncompensated out of true condition in a shaft or coupling remains, since it cannot be detected by usual measurement method. The hapless mechanic referred to above was in trouble because of this, any shift he found was because his second measurements were taken with the shaft turned to a position different from where it was for the first time. Use of the usual measurement technique is appropriate and adequate only when shafts are arrow-straight, couplings perfectly fitted to the propeller and transmission output shafts, and coupling faces are true to their machined bores. Unfortunately, The only

way to be certain you have these conditions is to have the shaft and coupling fitted together, set screws torqued down exactly as they will be in the boat, and total run out at the coupling face measured as zero by a competent machinist. All this of course, with the parts out of the boat. In any other case, a seeker of vibration-free cruising should suspect some out-of-trueness, sources of which are not hard to identify: touching a propeller to a shoal, heavy handed use of a hammer in removing a coupling, etc..

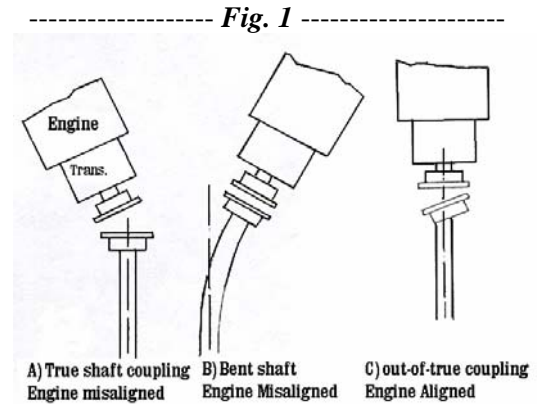

**Fig. 1** illustrates the problem we are going to solve. In A, the alignment is correctable by rotating and shifting the engine, bringing the difference measured across the coupling faces to zero. As the shaft and coupling are true, vibrations will be minimized. In B, lining the engine up with an out-of-true shaft (or coupling) will result in shaft whip and noticeable vibration. In C, the out-of-true coupling may cause shaft whip and vibration. You should note, however, that given an out-of-true shaft or coupling, as in C, aligning the engine to the axis of rotation of the shaft/coupling is the very best you can do; that is, whatever whip and vibration remains due to the out-of-trueness, will be the least you can get with that shaft. It will be less, for example, than what you’d have if you had aligned as in B. regardless of how the parts got warped, the technique that follows in this article will help you separate and determine (1) whether misalignment is present and if so how much, and (2) whether out-of-trueness is present in either or both the propeller shaft/coupling and the

transmission output shaft/coupling and how this out-of-trueness is oriented. Armed with this information, you can intelligently align things, minimize the effects of the out-of-trueness by rotating one coupling face relative to the other, and decide whether or not a haul-out is in order to have shafts and/or couplings trued up.

What follows is a “how-to” description of a procedure that will enable almost anyone to analyze his problem. The tiresome theory behind this procedure isn’t important. What is important is that this system can and will work for you. The steps will be as follows: marking the coupling, taking and recording the measurements, computing vertical and horizontal misalignment, correcting measured data to get trueness data, determining trueness at each coupling face, and judging the final results.

**Measurement procedure**

Mark the two flanges of the coupling on the outer circumference such that you can identify four measurement positions *Fig. 2*. These positions should be between the bolt holes, as burrs and nicks around the holes make a feeler gauge measurements, make sure the mating faces of the coupling are clean before you begin. You will need two feeler gauges covering a range of .001” to .030” in .001” increments

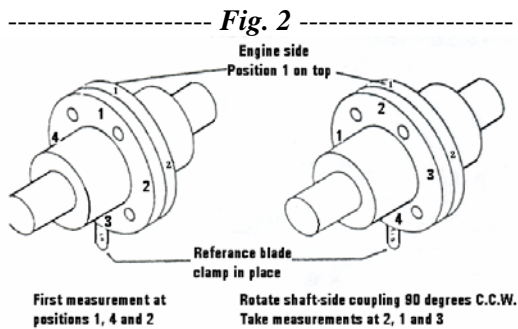

After this marking is done, a reference thickness feeler gauge blade is clamped firmly between the faces of the coupling at the bottommost measurement position. I use a small pair of vise-grip pliers for this, and an .015” feeler gauge. The rather hefty .015” reference blade will make it less likely that

the blade used for taking measurements will bend. When positioning the coupling halves, and before clamping the reference feeler gauge blade in place, insert a bolt through both halves to make sure the flanges are rotationally lined up. It isn’t necessary to put a nut on, as this is only to bring the measurement positions exactly together. The gap is then measured at position 1,4 and 2 as shown in *Fig.2*, and the width of the gap is recorded in thousands.

Next, unclamp the coupling, then rotate the shaft-side coupling 90 degrees counterclockwise as seen from the rear, keeping the engine-side coupling stationary with its position (1) remaining on top. Now again take measurements on the gaps at the top and two sides, this time at positions 2,1 and 3 on the shaft-side flange as shown on the right in *Fig.2*. Continue this procedure until you have taken measurements with all four positions at the top and have built a table similar to the one shown in *Fig.3*.

----- **Fig. 3** -----

Measurement Tables (In Thousandths Of An Inch)  
Reference Blade Thickness  $\text{-(.015)}^J$

Shaft-Side Coupling				Engine-Side Coupling			
Position At Top	Top Gap	Left Gap	Right Gap	Position At Top	Top Gap	Left Gap	Right Gap
1	17	18	8	1	17 <sup>G</sup>	18 <sup>H</sup>	8 <sup>J</sup>
2	21	18	10	2	19	18	8
3	25	22	10	3	21	20	8
4	21	22	6	4	19	20	6
Average Value $\text{-(21)}^A$ $\text{-(20)}^B$ $\text{-(8)}^C$				Average Value $\text{-(19)}^D$ $\text{-(19)}^E$ $\text{-(7)}^F$			
Verticle Misalignment (At Top): $A + D - C - J$							
Horizontal Misalignment (On Right): $C + F + H - B - E - I$							

To take a second set of measurements, return position 1 of the shaft-side flange to the top. Repeat the steps just described, but hold the shaft-side position 1 at the top, and rotate the engine-side coupling counterclockwise, as viewed from the rear, in 90 degree steps between measurements. These measurements should be recorded to form a table like the one shown on the right in *Fig.3*. It is obvious that the top line measurements in each *Fig.3* tables will be the same.

The seven sets of measured data you record in these two tables are used to analyze the problem. As a first step in the analysis, find the average value of each column in the two tables. The results of this for our example are shown as the last row in **Fig.3** tables. Note that the only tricky thing about this analysis scheme is keeping the signs of the numbers straight when you take the differences, compute averages, or add. Always use strict sign rules for addition or subtraction. If you have any difficulty, carefully work your way through the example provided here and that should clear it up.

### **Engine/shaft misalignment**

The misalignment will be found in two steps. First we'll find the amount of misalignment in the vertical plane and then we'll find it in the horizontal plane. The vertical plane misalignment will turn out to be the number of thousandths of an inch the top gap was too wide (if it turns out to be a positive number) or too narrow (if negative). The horizontal misalignment will be in thousandths of an inch, the right gap is too wide.(if positive) or too narrow (if negative). For the vertical determination, add the average values of the first column in each of the two tables together. In our example, the average from the shaft-side coupling table is 21 and the average from the engine-side coupling table is 19. The sum of these is 40. Subtract from this number the sum of the reference feeler gauge blade thickness, 15, and the first top gap measurement from the engine-side coupling table, 17. The result of this,  $40 - 32 = +8$ , gives us the misalignment in the vertical plane. These steps are summarized by the formula given at the bottom of **Fig. 3**.

We now know that the front of the engine is too low (or the back is too high) as indicated by the fact that the average gap at the top of the coupling is .008" wider than at the bottom. We know its wider because of the positive sign. Had this number come out negative, this would have meant the gap was narrower at the top.

The misalignment in the horizontal plane is found next. Take the sum of the averages for the *right* gap measurements in both tables, which for this example are 8 and 7. Add to these the first measurements of the *left* gap from the engine-side coupling table. This turns out to be  $8 + 7 + 18 = 33$ . Now take the sum of the average *left* gap measurements from the two tables, and to this add the first measurement of the *right* gap from the engine-side coupling table. This calculation is  $20 + 19 + 6 = +45$ . Now subtract the second total from the first, or  $+33 - 45 = -12$ . Now steps are also summarized by the formula given in **Fig. 3**. This tells us the horizontal misalignment is twelve thousandths, and that the average *right* side gap is too narrow, as indicated by the negative sign. Had the sign been positive, the reverse would have been the case. Thus the front of the engine is too far to the right (or the rear too far left), resulting in an average gap on the right .012" narrower than that on the left.

Note carefully the order in which these steps were taken, and also what number was subtracted from what. The formulas will help you keep the signs right. Simply pull the numbers from the table as indicated by the circles and use them in the formulas as shown.

### **Out of trueness**

Now that we have determined the misalignment, it is a simple matter to apply those figures, as a correction factor, to our measurement data. Then we can see what is left. Take the two tables from **Fig.3** and construct two more corresponding to those, except subtract 8 (the vertical plane misalignment) from each of the numbers in the first two columns, subtract 6 (half the horizontal misalignment) from each number in the second columns, and add 6 (the other half of the horizontal misalignment) to each number in the third columns. The reason for splitting the horizontal misalignment in half before correcting the tables is that the reference blade was used in the vertical plane rather than the horizontal, and the

table corrections must be made as though the coupling halves are rocking about a vertical axis.

----- **Fig.4** -----

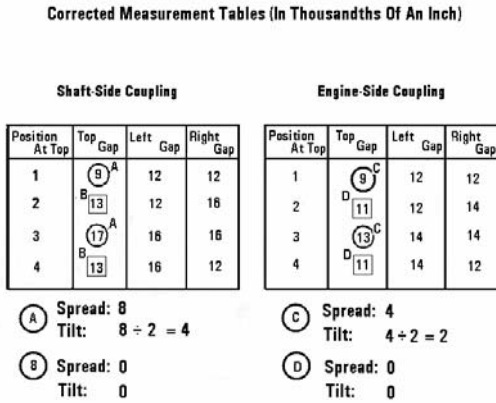

The result of these corrections is shown in **Fig. 4**. The tables given there represent what we would have measured if the alignment had been perfect. In other words, these tables give us our out-of-trueness data. There is no need to calculate column averages this time.

We will find the out-of-trueness in two steps for each coupling face. First examine the column one data for the shaft-side face for maximum spread between opposite measurement positions (e.g. 1 to 2 and 2 to 4). When 1 was up, we measured 9; when 3 was up, we measured 17. This is a spread of 8. Half of that spread (or 4) is the out-of-true tilt of the coupling face as you move from position 3 to position 1. If we draw a rear view of the shaft-side coupling and record this information on that drawing, we get something like Fig.5.

----- **Fig. 5** -----

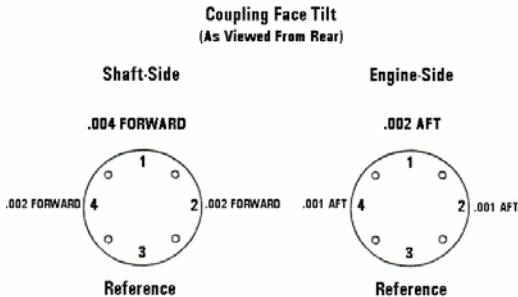

We know that position 1 is tilted forward relative to position 3 since the gap was narrower with position 1 on top. We also note from column one that the spread from position 2 to position 4 is zero, or that there is no tilt in moving from position 2 to 4.

We assume that positions 2 and 4 are both .002 forward of our reference position 3, because this is half of the distance the face is tilted forward at position 1. Thus we have built up a picture of the tilt of this coupling face relative to the axis of rotation of the coupling-shaft assembly.

We analyze the engine-side coupling in a similar fashion. On examining the table for the engine side of the coupling, we find a maximum spread of 4 between positions 1 and 3, or a tilt of half (4 divided by 2 = 2) as you move from positions 3 to 1. This time, as shown on the right in Fig. 5, the tilt is such that position 1 is farther aft than position 3. We know this because we had the smaller measurement of the two when position 1 was up. We examine the other pair (2,4) and conclude again that there is no tilt along the line joining these two positions across the coupling. Again, assuming these positions are in the same plane as positions 1 and 3, we conclude that they are one-thousandth farther aft than position 3 (half of the two thousandth aft displacement of position 1 relative to the reference blade position).

We can see by examining the coupling face tilts as depicted in **Fig. 5** that bringing those faces together as they are is going to leave a .006" gap at position 3. An out-of-trueness condition of this size will cause whip & vibration. But if we turn either face one-half turn, or 180 degrees, so that position 1 of the engine-side coupling and position 3 of the shaft-side coupling are together, we will reduce this gap, or out-of-true situation, to a composite of only .002", possibly an acceptable amount.

**What Now?**

The engine misalignment can be corrected by proper shifting of the engine on its bed.

Do the alignment first, before matching faces, because if you keep your coupling faces with each position 1 at top as you horse the engine around, you can use row one of either of the two tables in Fig. 4 as the “desired” set of measurements that you want when you’re through aligning. Recall that these are the “should measurement” figures, assuming perfect alignment.

What to do about out-of-trueness will depend on its magnitude. In our example, which comes from an actual case, it seemed that if we matched the coupling faces so that position 1 of the aft face lined up with position 3 of the forward face, the residual out-of-trueness might lie within allowable tolerances. In fact, in this case, after the engine alignment was completed and the matching was done, a repeat of this measurement analysis procedure confirmed that we were within tolerance. A subsequent test underway confirmed that the vibration level had been reduced significantly, but without the time and expense of a haul-out to straighten the suspect shaft. Each case must of course be decided on as it’s analyzed.

It’s a good idea to always conclude your work with a repeat of the measurement and analysis procedure just before you finally bolt the couplings back together. This is done as a final check on how far you’ve gotten things toward where they should be, and also to catch any errors you may have made. It’s also a very good way to build up your experience log to help you in judging the next case.

## **Alignment goals**

Careful measurement and patience and care in engine mounting changes can usually get the measured misalignment to within a one-thousandth (.001”) difference across the face of a four-inch coupling. Alignment this close will ensure virtually no misalignment-induced vibration and noise. My experience has been that when either the vertical or horizontal plane figure approaches .004”, problems start.. Thus, the alignment goal should be zero difference across a four-inch coupling, with an allowable tolerance of no more than .002”. This tolerance includes any out-of-trueness. Said another way, the alignment should be nearly perfect, and only out-of-trueness errors should remain. For couplings larger or smaller than four inches, a good rule of thumb for allowable tolerance is .0005” per inch of coupling face diameter.

With the technique presented in this article, the mechanic or do-it-yourselfer has the information he needs to tackle the job. He can clearly separate misalignment from out-of-true shaft or coupling problems. He can then decide with confidence whether vibration and noise problems can be reduced by alignment and/or matching, or whether a haul-out and turning is required. Thirty minutes of measurement work plus another thirty of cipherin’ will put you well on the way to quieter cruising.